

APSX-PIM Max Mold Platens Daylight Opening

APSX-PIM

TOP VIEW

POWER: 110V

4' BY 1' FOOTPRINT

NO ASSEMBLY REQUIRED

6" BY 4.8" MOLD SIZE

TEST MOLD INSTALLED

30 CU-CM (1.83 CU-IN) SHOT

60 SECS CYCLE TIME

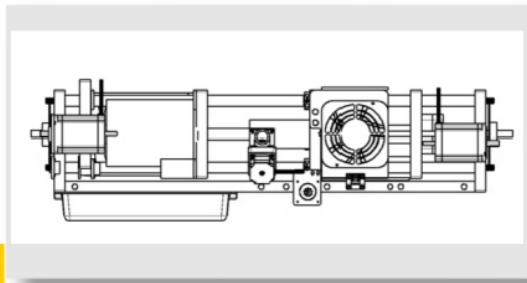

4' BY 2' TABLETOP

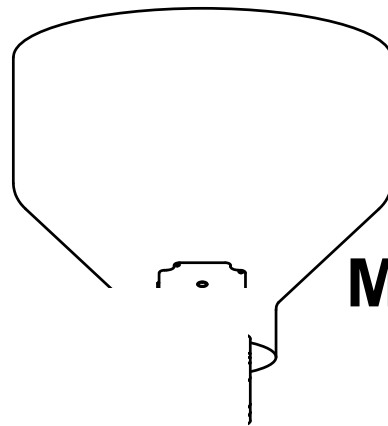

MAX DAYLIGHT 7.5"

Ejector Distance

5.47

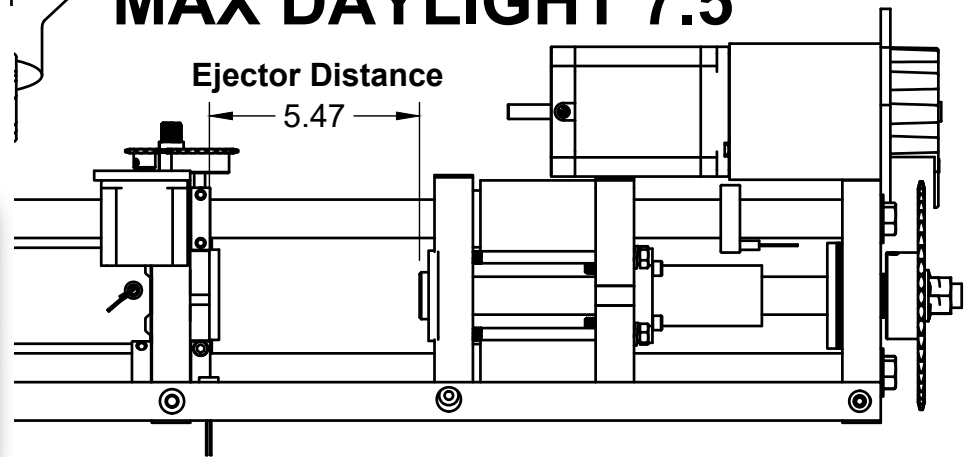

YouTube Video: <https://youtu.be/yAMkoBTmxeY?si=OsNcznFXUR40PHXL>